

# FiFo station

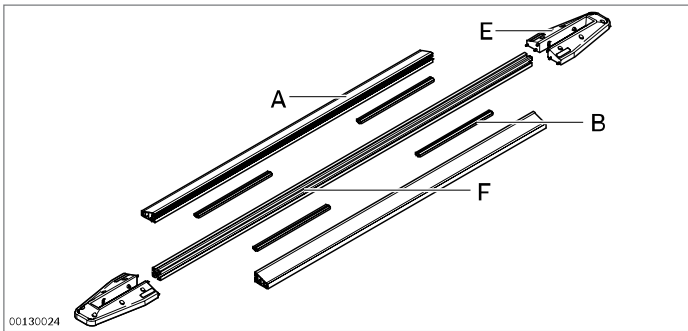

00137/599

- ▶ Standardized delivery routes for clearly organized and highly transparent production operations
  - ▶ Clear visualization to help minimize inventories
  - ▶ Implementation of the kanban principle
  - ▶ Structured material supply system with efficient, well-defined processes to help find required materials fast
  - ▶ Easy tracing of faults and malfunctions through observation of the FiFo principle
  - ▶ Modular system lets you adapt the layout to your needs and to your space
- ▶ Flow rack systems can be integrated to save space. The flow rack is set up on the FiFo tracks, light parts are stored in the flow rack and heavy parts on floor rollers or material shuttles in the FiFo station.
  - ▶ Information supplied by attaching information boards
  - ▶ A transverse profile can be installed to set a height limit for materials

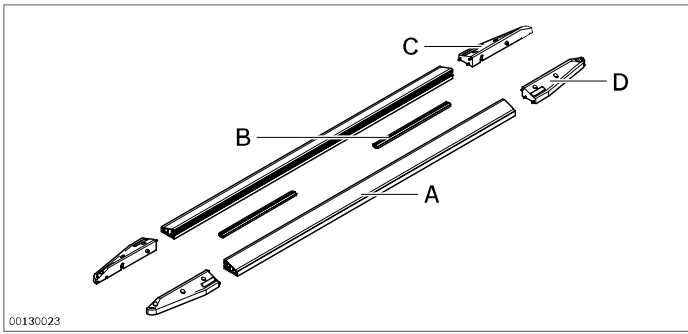

### Components

- ▶ Guide rail fastened to floor using adhesive strips, end caps may also be screwed in place (if required)
- ▶ Adapter for connecting two guide rails, or a guide rail with a 30x30 profile
- ▶ Large end caps for integrating a 30x30 profile for use in installing flow rack systems, information boards and height limits. Since the guide rails are flat-sided, setup can be done using a profile of width 45.
- ▶ Guide rail color: Yellow
- ▶ End cap color: Black

	L (mm)			No.
<b>A</b> Guide rail	1200		10	<b>3 842 540 012</b>
	2400		10	<b>3 842 539 894</b>
<b>B</b> Adapter			20	<b>3 842 539 898</b>
<b>C</b> Right end cap, small			10	<b>3 842 539 895</b>
<b>D</b> Left end cap, small			10	<b>3 842 539 896</b>
<b>E</b> End cap, large			10	<b>3 842 539 897</b>
<b>F</b> Profile 30x30	50 ... 5600	1		<b>3 842 993 703/L</b>
	5600	20		<b>3 842 509 178</b>

